

Electromagnetic compatibility (EMC) —

Part 4-12: Testing and measurement techniques — Ring wave immunity test

www.lisungroup.com

The European Standard EN 61000-4-12:2006 has the status of a
British Standard

ICS 33.100.20

National foreword

This British Standard is the UK implementation of EN 61000-4-12:2006. It is identical with IEC 61000-4-12:2006. It partially supersedes BS EN 61000-4-12:1996.

BS EN 61000-4-12:2006 constitutes a technical revision of the characteristics and performance of the test equipment but addresses only the ring wave immunity test. The content of BS EN 61000-4-12:1996 regarding damped oscillatory waves is replaced by BS EN 61000-4-18:2007. The date of withdrawal of BS EN 61000-4-12:1996 is 1 March 2010 which is the date of withdrawal published in BS EN 61000-4-18. For undated references to BS EN 61000-4-12, the ring wave test in BS EN 61000-4-12:2006 needs to be used after 1 November 2009. BS EN 61000-4-12:1996 may continue to be referenced for the damped oscillatory wave until 1 March 2010.

The UK participation in its preparation was entrusted by Technical Committee GEL/210, EMC — Policy committee, to Subcommittee GEL/210/12, EMC — Basic and generic standards.

A list of organizations represented on GEL/210/12 can be obtained on request to its secretary.

This publication does not purport to include all the necessary provisions of a contract. Users are responsible for its correct application.

Compliance with a British Standard cannot confer immunity from legal obligations.

Amendments issued since publication

Amd. No.	Date	Comments
17250 Corrigendum No. 1	31 August 2007	Revision of national foreword

This British Standard was published under the authority of the Standards Policy and Strategy Committee on 28 February 2007

© BSI 2007

ISBN 978 0 580 60056 2

English version

Electromagnetic compatibility (EMC)
Part 4-12: Testing and measurement techniques -
Ring wave immunity test
(IEC 61000-4-12:2006)

Compatibilité électromagnétique (CEM)
Partie 4-12: Techniques d'essai
et de mesure -
Essai d'immunité à l'onde
sinusoïdale amortie
(CEI 61000-4-12:2006)

Elektromagnetische Verträglichkeit (EMV)
Teil 4-12: Prüf- und Messverfahren -
Störfestigkeit gegen gedämpfte
Sinusschwingungen (Ringwave)
(IEC 61000-4-12:2006)

This European Standard was approved by CENELEC on 2006-11-01. CENELEC members are bound to comply with the CEN/CENELEC Internal Regulations which stipulate the conditions for giving this European Standard the status of a national standard without any alteration.

Up-to-date lists and bibliographical references concerning such national standards may be obtained on application to the Central Secretariat or to any CENELEC member.

This European Standard exists in three official versions (English, French, German). A version in any other language made by translation under the responsibility of a CENELEC member into its own language and notified to the Central Secretariat has the same status as the official versions.

CENELEC members are the national electrotechnical committees of Austria, Belgium, Cyprus, the Czech Republic, Denmark, Estonia, Finland, France, Germany, Greece, Hungary, Iceland, Ireland, Italy, Latvia, Lithuania, Luxembourg, Malta, the Netherlands, Norway, Poland, Portugal, Romania, Slovakia, Slovenia, Spain, Sweden, Switzerland and the United Kingdom.

CENELEC

European Committee for Electrotechnical Standardization
Comité Européen de Normalisation Electrotechnique
Europäisches Komitee für Elektrotechnische Normung

Central Secretariat: rue de Stassart 35, B - 1050 Brussels

Foreword

The text of document 77B/509/FDIS, future edition 2 of IEC 61000-4-12, prepared by SC 77B, High frequency phenomena, of IEC TC 77, Electromagnetic compatibility, was submitted to the IEC-CENELEC parallel vote and was approved by CENELEC as EN 61000-4-12 on 2006-11-01.

This European Standard supersedes EN 61000-4-12:1995 + A1:2001.

It constitutes a technical revision of the characteristics and performance of the test equipment. It only addresses the ring wave immunity test.

The following dates were fixed:

- latest date by which the EN has to be implemented at national level by publication of an identical national standard or by endorsement (dop) 2007-08-01
- latest date by which the national standards conflicting with the EN have to be withdrawn (dow) 2009-11-01

Annex ZA has been added by CENELEC.

Endorsement notice

The text of the International Standard IEC 61000-4-12:2006 was approved by CENELEC as a European Standard without any modification.

www.Lisungroup.cc

CONTENTS

INTRODUCTION.....	5
1 Scope.....	6
2 Normative references	6
3 Terms and definitions	6
4 General	8
4.1 Description of the phenomenon	8
4.2 Relevant parameters	9
5 Test levels.....	10
6 Test equipment.....	10
6.1 Test generator.....	10
6.2 Coupling/decoupling network specifications.....	13
7 Test set-up	14
7.1 Test of power supply ports	16
7.2 Test of input/output ports.....	16
7.3 Test of communication ports.....	16
7.4 Earthing connections.....	16
7.5 Equipment under test	17
7.6 Coupling/decoupling networks	18
8 Test procedure	18
8.1 Laboratory reference conditions	19
8.2 Execution of the test.....	19
9 Evaluation of test results	21
10 Test report.....	21
Annex A (informative) Information on test levels for the ring wave	30
Annex ZA (normative) Normative references to international publications with their corresponding European publications.....	32
Bibliography.....	31
Figure 1 – Waveform of the ring wave (open circuit voltage and short circuit current)	9
Figure 2 – Example of schematic circuit of the test generator for ring wave	11
Figure 3 – Example of test set-up for table-top equipment using the ground reference plane.....	15
Figure 4 – Example of test set-up for floor-standing equipment using the ground reference plane.....	15
Figure 5 – AC/DC power supply port, single phase, line-to-line test	22
Figure 6 – AC/DC power supply port, single phase, line-to-ground test	22
Figure 7 – Example of test setup for capacitive coupling on a.c. lines (3 phases) – line L3 to line L1 coupling	23
Figure 8 – Example of test setup for capacitive coupling on a.c. lines (3 phases) – line L3 to ground coupling.....	24

Figure 9 – Example of test setup for unshielded unsymmetrical interconnection lines – line-to-line and line-to-ground coupling via capacitors 25

Figure 10 – Example of test setup for unshielded unsymmetrical interconnection lines – line-to-line and line-to-ground coupling via arrestors 26

Figure 11 – Example of test setup for unshielded unsymmetrical interconnection lines – line-to-line and line-to-ground coupling via a clamping circuit 27

Figure 12 – Example of test setup for unshielded symmetrical interconnection lines (communication lines) – lines-to-ground coupling via arrestors 28

Figure 13 – Test of a system with communication ports with fast operating signals (generator output earthed) 29

Table 1 – Test levels for ring wave 10

www.Lisungroup.cc

INTRODUCTION

IEC 61000 is published in separate parts according to the following structure:

Part 1: General

General considerations (introduction, fundamental principles)
Definitions, terminology

Part 2: Environment

Description of the environment
Classification of the environment
Compatibility levels

Part 3: Limits

Emission limits
Immunity limits (in so far as they do not fall under the responsibility of the product committees)

Part 4: Testing and measurement techniques

Measurement techniques
Testing techniques

Part 5: Installation and mitigation guidelines

Installation guidelines
Mitigation methods and devices

Part 6: Generic standards

Part 9: Miscellaneous

Each part is further subdivided into several parts, published either as international standards or as technical specifications or technical reports, some of which have already been published as sections. Others will be published with the part number followed by a dash and a second number identifying the subdivision (example: 61000-6-1).

This part is an International Standard which gives immunity requirements and test procedures related to ring waves.

ELECTROMAGNETIC COMPATIBILITY (EMC) –

Part 4-12: Testing and measurement techniques – Ring wave immunity test

1 Scope and object

This part of IEC 61000 relates to the immunity requirements and test methods for electrical and electronic equipment, under operational conditions, to non-repetitive damped oscillatory transients (ring waves) occurring in low-voltage power, control and signal lines supplied by public and non-public networks.

The object of this basic standard is to establish the immunity requirements and a common reference for evaluating in a laboratory the performance of electrical and electronic equipment intended for residential, commercial and industrial applications, as well as of equipment intended for power stations and substations, as applicable.

NOTE As described in IEC Guide 107, this is a basic EMC publication for use by product committees of the IEC. As also stated in Guide 107, the IEC product committees are responsible for determining whether this immunity test standard should be applied or not, and if applied, they are responsible for determining the appropriate test levels and performance criteria. TC 77 and its sub-committees are prepared to co-operate with product committees in the evaluation of the value of particular immunity tests for their products.

The purpose of this standard is to define:

- test voltage and current waveforms;
- ranges of test levels;
- test equipment;
- test set-up;
- test procedure.

2 Normative references

The following referenced documents are indispensable for the application of this document. For dated references, only the edition cited applies. For undated references, the latest edition of the referenced document (including any amendments) applies.

IEC 60050(161): *International Electrotechnical Vocabulary (IEV) – Chapter 161: Electromagnetic compatibility*

3 Terms and definitions

For the purpose of this document, the following terms and definitions, together with those in IEC 60050-161 apply.

NOTE Several of the most relevant terms and definitions from IEC 60050-161 are presented among the definitions below.

3.1

burst

sequence of a limited number of distinct pulses or an oscillation of limited duration

[IEV 161-02-07]

**3.2
calibration**

set of operations which establishes, by reference to standards, the relationship which exists under specified conditions, between an indication and a result of a measurement

NOTE 1 This term is based on the "uncertainty" approach.

NOTE 2 The relationship between the indications and the results of measurement can be expressed, in principle, by a calibration diagram.

[IEV 311-01-09]

**3.3
coupling**

interaction between circuits, transferring energy from one circuit to another

**3.4
coupling network**

electrical circuit for the purpose of transferring energy from one circuit to another

**3.5
decoupling network**

electrical circuit for the purpose of preventing test voltages applied to the EUT (equipment under test) from affecting other devices, equipment, or systems which are not under test

**3.6
immunity (to a disturbance)**

the ability of a device, equipment, or system to perform without degradation in the presence of an electromagnetic disturbance

[IEV 161-01-20]

**3.7
port**

particular interface of the EUT with the external electromagnetic environment

**3.8
rise time**

the interval of time between the instants at which the instantaneous value of a pulse first reaches 10 % value and then the 90 % value

[IEV 161-02-05, modified]

**3.9
transient (adjective and noun)**

pertaining to or designating a phenomenon or a quantity which varies between two consecutive steady states during a time interval short compared with the time-scale of interest

[IEV 161-02-01]

**3.10
verification**

set of operations which is used to check the test equipment system (e.g. the test generator and the interconnecting cables) and to demonstrate that the test system is functioning within the specifications given in Clause 6

NOTE 1 The methods used for verification may be different from those used for calibration.

NOTE 2 The procedure of 6.1.2 and 6.2.2 is meant as a guide to insure the correct operation of the test generator and other items making up the test set-up, so that the intended waveform is delivered to the EUT.

NOTE 3 For the purpose of this basic EMC standard this definition is different from the definition given in IEV 311-01-13.

4 General

4.1 Description of the phenomenon

The ring wave (described in Figure 1) is a typical oscillatory transient, induced in low-voltage cables due to the switching of electrical networks and reactive loads, faults and insulation breakdown of power supply circuits or lightning. It is, in fact, the most diffused phenomenon occurring in power supply (HV, MV, LV) networks, as well as in control and signal lines.

The ring wave is representative of a wide range of electromagnetic environments of residential, as well as industrial installations. It is suitable for checking the immunity of equipment in respect of the above-mentioned phenomena, which give rise to pulses characterized by sharp front-waves that, in the absence of filtering actions, are in the order of 10 ns to a fraction of μs . The duration of these pulses may range from 10 μs to 100 μs .

The rise time and duration of the parameters are subject to modification, depending on the propagation media and path.

The propagation of the wave in the lines (power and signal) is always subject to reflections, due to the mismatching impedance (the lines are terminated on their own loads or connected to protection devices, input line filters, etc.). These reflections produce oscillations, whose frequency is related to the propagation speed. The presence of parasitic parameters (stray capacitance of components like motors, transformer windings, etc.) are other conditioning factors.

The rise time is reduced to slowing down due to the low-pass characteristic of the line involved in the propagation. This modification is more relevant for the fast rise times (in the order of 10 ns), and less relevant for values in the range of a fraction of μs .

The resultant phenomenon at the equipment ports is an oscillatory transient, or ring wave. This ring wave with a defined 0,5 μs rise time and 100 kHz oscillation frequency has been determined to be typical and is widely used by some industries for testing products.

Another cause of the ring wave is lightning, which itself is characterized by a unidirectional waveform (standard 1,2/50 μs pulse). Circuits subjected to the indirect effects of lightning (inductive coupling among lines) are influenced by the derivative of the primary pulse and the coupling mechanisms involved, which gives rise to oscillations. The characteristics of the resulting ring wave depend on the reactive parameters of the ground circuits, metal structures involved in the lightning current flow, and the propagation in the low-voltage transmission lines.

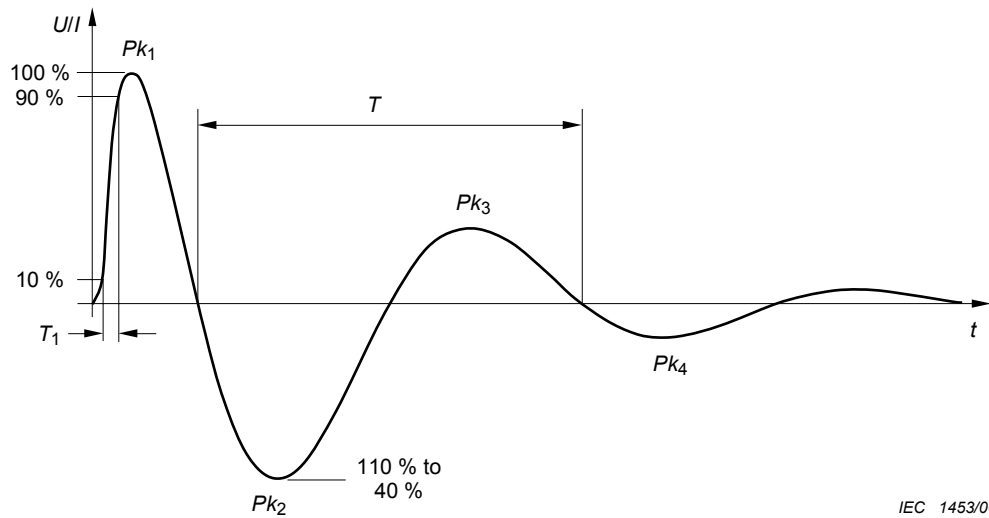

Key

- T_1 Rise time
- T Oscillation period

NOTE Only Pk_1 is specified for the current waveform.

Figure 1 – Waveform of the ring wave (open circuit voltage and short circuit current)

Other IEC standards, such as IEC 61000-4-5, refer to the 1,2/50 μ s standard lightning pulse, which may be considered to be complementary to ring wave described in this document.

It is the responsibility of the product committees to define the most appropriate test, according to the phenomenon considered as relevant.

4.2 Relevant parameters

4.2.1 Repetition rate

The repetition rate of the transient is directly related to the frequency of occurrence of the primary phenomenon. It is higher whenever the primary cause is the load switching in control lines, and less frequent in the case of faults and lightning. The occurrence may range from 1/s to 1/month or 1/year.

The repetition rate may be increased in order to reduce the duration of the test. However, it should be selected according to the characteristics of the transient protectors involved.

4.2.2 Phase angle

Equipment failures related to ring wave on power supply sources can depend on the phase angle of the ac mains at which the transient is applied. When a protection element operates during a ring-wave test, power-follow might occur depending on the phase angle at which the transient occurs. Power-follow is the current from the connected power source that flows through a protective element, or from any arc in the EUT both during and following the transient.

For semiconductors, the phenomenon may be related to the conduction state of the device at the time the ring wave occurs. Semiconductor parameters that might be involved include forward and reverse recovery characteristics and secondary breakdown performance.

Devices most likely to fail in a phase-related way are semiconductors involved in the power input circuitry. Other devices in different areas of the EUT might also exhibit such failure modes.

5 Test levels

The preferred test levels for the ring wave applicable to power, signal and control ports of the equipment, are given in Table 1. The test level is defined as the voltage of the first peak (maximum or minimum) in the test waveform (Pk_1 in Figure 1).

Different levels may apply to power, signal and control ports. The level(s) used for signal and control ports shall not differ by more than one level from that used for power supply ports.

Table 1 – Test levels for ring wave

Level	Line-to-ground kV	Line-to-line kV
1	0,5	0,25
2	1	0,5
3	2	1
4	4	2
x^a	x	x
^a x can be any level, above, below or in-between the other levels. This level can be given in the product standard.		

The applicability of the ring wave test, shall refer to the product specification.

The test levels from Table 1 should be selected in accordance with the most realistic installation and environmental conditions.

The immunity tests are correlated with these levels in order to establish a performance level for the environment in which the equipment is expected to operate, taking into account the primary phenomena and the installation practices which determine the classes of the electromagnetic environment.

The selection of the test levels should be done on the basis of the applicability to a given location or installation.

6 Test equipment

6.1 Test generator

The generator output shall have the capability to operate under short-circuit conditions. A block diagram of a representative ring wave generator is shown in Figure 2.

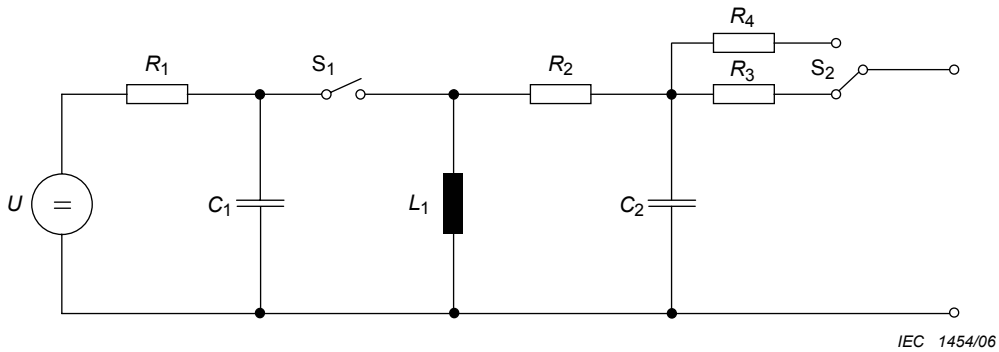

Key

- | | |
|----------------------------------|-----------------------------------|
| U : high-voltage source | R_3 : 30 Ω resistor |
| C_1 : energy storage capacitor | R_4 : 12 Ω resistor |
| C_2 : filter capacitor | L_1 : oscillating circuit coil |
| R_1 : charging resistor | S_1 : high-voltage switch |
| R_2 : filter resistor | S_2 : output impedance selector |

Figure 2 – Example of schematic circuit of the test generator for ring wave

6.1.1 Impedance values

Two values of impedance have been selected to test power supply ports: 12 Ω and 30 Ω . These values are applicable, respectively, to short and long branch circuits, corresponding to the relative distance of the power supply source from the main distribution network. They represent a technical compromise, because they include the need to test EUT ports normally interfaced with low impedance circuits, according to the values given in IEC 60816. In addition, they cover the requirements to test the transients protection devices, such as the metal oxide varistors, Zener diodes, etc., installed in the EUT.

6.1.2 Characteristics and performance of the test generator

The test generator is a single-shot ring wave generator with the following characteristics, measured as it is to be applied to the EUT port. If applied via a coupling/decoupling network, the characteristics are to be as specified at the output of that network.

The generator output shall be floating. This condition is necessary to test EUT control and signal ports in line-to-line mode. It is not necessary for power ports and line-to-ground mode tests of control and signal ports.

The generator shall have provisions to prevent the emission of heavy disturbances that may be injected in the power supply network, or may influence the test results.

Specifications:

- voltage rise time (T_1 in Figure 1): 0,5 $\mu\text{s} \pm 30\%$ (open-circuit condition);
- current rise time (T_1 in Figure 1): $\leq 1 \mu\text{s}$ (short-circuit condition);

- voltage oscillation frequency, Note 1: 100 kHz \pm 10 %;
- decaying (Voltage only; see Figure 1)
 - 0,4 < Ratio of Pk_2 to Pk_1 < 1,1
 - 0,4 < Ratio of Pk_3 to Pk_2 < 0,8
 - 0,4 < Ratio of Pk_4 to Pk_3 < 0,8
 - No requirements for other peaks.
- transients' repetition: 1 to 60 transients per minute;
- output impedance, Note 2: 12 Ω and 30 Ω \pm 20 % (switchable);
- open circuit voltage (Pk_1 value
See Figure 1) 250 V to 4 kV (\pm 10 %)
- short-circuit current (Pk_1 value
See Figure 1) 333 A \pm 10 % for 12 Ω generator setting;
133 A \pm 10 % for 30 Ω generator setting;
- phase relationship with the power frequency: in a range between 0° to 360° relative to
the phase angle of the a.c. line voltage
to the equipment under test, with a
tolerance of $\pm 10^\circ$
- polarity of the first half period: positive and negative.

NOTE 1 Oscillation frequency is defined as the reciprocal of the period between the first and third zero crossings after the initial peak. This period is shown as T in Figure 1.

NOTE 2 Output impedance is calculated as open circuit voltage divided by short circuit current.

The waveform of the ring wave (open-circuit voltage and short-circuit current) with peak points marked, is given in Figure 1. An example of a schematic circuit of the generator is given in Figure 2.

6.1.3 Verification of the characteristics of the test generator

The verification procedure is meant as a guide to insure the correct operation of the test generator, coupling/decoupling networks, and other items making up the test set-up so that the intended waveform is delivered to the EUT.

In order to make it possible to compare the results of different test generators, the most essential characteristics shall be verified.

The characteristics to be verified in accordance with the parameters of 6.1.2 are the following:

- rise time (voltage and current);
- oscillation frequency;
- decaying;
- repetition frequency;
- open-circuit voltage;
- short-circuit current.

The verifications shall be carried out with voltage or current probes (as applicable) and with oscilloscope or other equivalent measurement instrumentation with 20 MHz minimum bandwidth. The waveform characteristics shall be verified at the EUT port of each CDN used for the immunity test, or directly at the output of the test generator if no CDN is to be used. The permissible inaccuracy of the measurements is ± 10 %.

6.2 Coupling/decoupling network specifications

The coupling/decoupling network (CDN) provides both the ability to apply the test voltage in either line-to-ground or line-to-line mode to the mains, signal and control ports of the EUT (equipment under test), and prevents test voltage from affecting any auxiliary equipment needed to perform the test. The waves shall be within the tolerances of 6.1.2 at the EUT port of the CDN. However, if non-linear coupling devices such as gas arrestors or breakdown avalanche diodes are used, the characteristics of the ring waveform can be changed significantly.

The specifications, common to the networks for power supply, as well as for the input/output ports, are given below. Additional unique specifications are given in 6.2.1 and 6.2.2.

The coupling network shall be provided with coupling capability suitable for the selected impedance of the test generator, i.e. 3 μ F (minimum).

The coupling capacitors may be replaced by other types of coupling devices such as arrestors or clamping circuits.

The coupling/decoupling network shall be provided with a dedicated earth terminal.

Verification to the specifications of 6.1.2 shall be carried out with an oscilloscope, or equivalent measuring instrument having a minimum bandwidth of 20 MHz.

6.2.1 Coupling/decoupling network for a.c./d.c. power supply ports

The output waveforms from the coupling/decoupling network shall meet the same requirements set forth in 6.1.2 for the test generator itself.

The a.c. mains voltage drop at the EUT connector of the coupling/decoupling network shall be less than 10 % at the specified current rating of the coupler.

Specifications:

The residual surge voltage on the power supply inputs of the decoupling network when the EUT is disconnected shall not exceed 15 % of the applied test voltage or twice the rated peak voltage of the coupling/decoupling network, whichever is higher.

- insulation withstand capability of the coupling devices with the 1,2/50 μ s wave: 5 kV;
- current capability: as required for the EUT;
- number of phases: as required for the EUT.

NOTE Minimum values of line-to-ground and line-to-line mode decoupling may not be sufficient to protect auxiliary equipment being used to facilitate the test.

6.2.2 Coupling/decoupling network for signal and control ports

The network has the same specifications as given in 6.2.1 with the exception below:

The residual surge voltage on the power supply inputs of the decoupling network when the EUT is disconnected shall not exceed 15 % of the applied test voltage or twice the rated peak voltage of the coupling/decoupling network, whichever is higher.

The minimum decoupling attenuation may not be sufficient to protect auxiliary signal sources, and additional protection devices may be required.

The network may consist of single units in order to give the possibility of testing input/output ports with single circuits or grouping of circuits (for example, multi-wire with a common).

7 Test set-up

The test set-up includes the following equipment:

- earthing connections, ground (reference) plane (GRP);
- EUT;
- test generator;
- measurement instrumentation;
- coupling and decoupling network;
- auxiliary instrumentation.

Examples of test set-up are given in the following figures:

Figure 3 – Example of test set-up for table-top equipment using the ground reference plane;

Figure 4 – Example of test set-up for floor-standing equipment using the ground reference plane.

www.Lisungroup.co

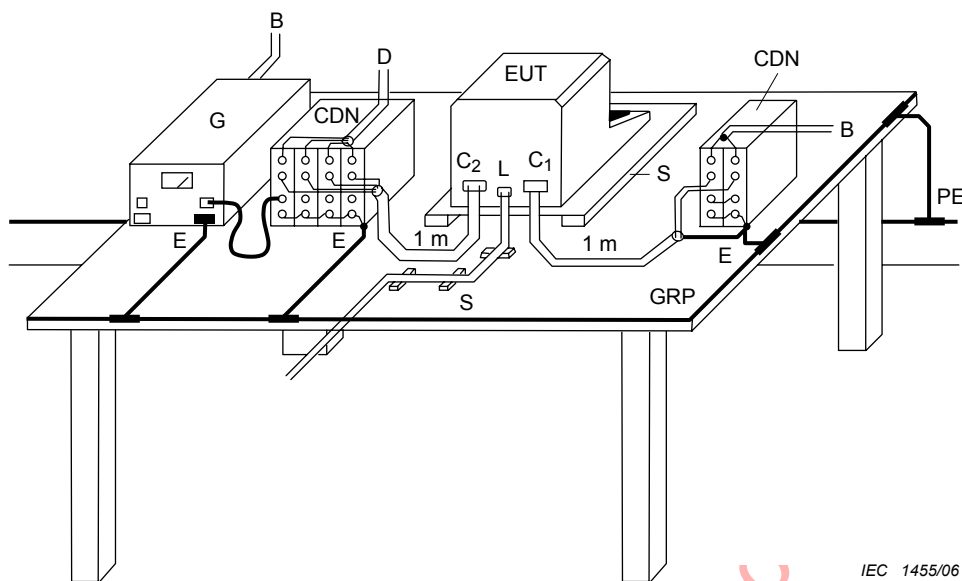

IEC 1455/06

NOTE Earth connections should be as short as practically possible.

- | | |
|--------------------------|----------------------------------|
| PE: protective earth | EUT: equipment under test |
| B: power supply source | G: test generator |
| C1: power supply port | L: communication port |
| C2: input/output port | GRP: ground reference plane |
| D: signal/control source | CDN: coupling/decoupling network |
| E: earth connection | S: insulating support |

Figure 3 – Example of test set-up for table-top equipment using the ground reference plane

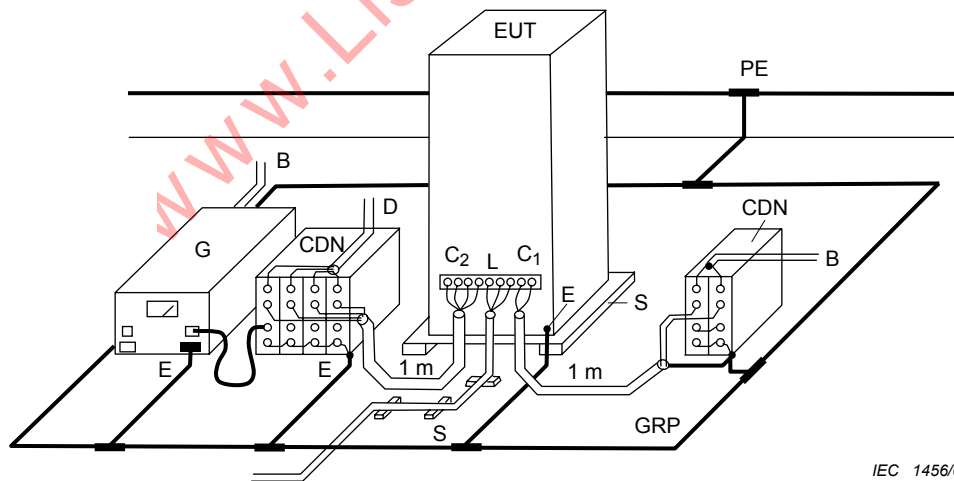

IEC 1456/06

NOTE Earth connections should be as short as practically possible.

- | | |
|--------------------------|----------------------------------|
| PE: protective earth | EUT: equipment under test |
| B: power supply source | G: test generator |
| C1: power supply port | L: communication port |
| C2: input/output port | GRP: ground reference plane |
| D: signal/control source | CDN: coupling/decoupling network |
| E: earth connection | S: insulating support |

Figure 4 – Example of test set-up for floor-standing equipment using the ground reference plane

7.1 Test of power supply ports

The test voltage shall be applied through the coupling/decoupling network.

In general, the impedance of the test generator shall be as follows:

- EUT ports connected to major feeders shall be tested with 12 Ω generator impedance;
- EUT ports connected to outlets shall be tested with 30 Ω generator impedance.

Product committees may specify tests using either 12 Ω or 30 Ω generator impedance as required.

7.2 Test of input/output ports

The test voltage shall be applied via the coupling/decoupling network, provided the network is suitable for the operating signal of the EUT ports.

The impedance of the coupling path shall be 12 Ω or 30 Ω .

7.3 Test of communication ports

The test of communication ports of a system (fast operating signals involved) with the application of test voltage via the coupling/decoupling network may cause degradation of the operating signals. In that situation, the test voltage shall be applied between the cabinets of the equipment interconnected (EUT 1 and EUT 2), according to Figure 13. The output impedance of the test generator shall be 12 Ω .

The maximum cable length for this test is 20 m.

The signal cables shall be connected according to the product specifications, which shall give information on any protection measure to be taken.

Whenever EUT 1 is an auxiliary equipment (simulator), a preliminary verification of the immunity of the simulator shall be made; in case of lack of immunity of the simulator, and whenever no provisions can be taken to avoid susceptibility, the test will be carried out with the following objectives:

- the communication port is not damaged;
- the communication is corrupted only during the application of the test voltage;
- the EUT performances, other than ones related to communications, are not affected.

7.4 Earthing connections

In performing the tests, the safety earthing requirements of the manufacturer of the EUT and of the test equipment shall be observed.

In setting up the test configuration, the earthing of the test generator, of the coupling/decoupling network, of EUT and auxiliary equipment may be achieved by using an existing ground reference plane (GRP), or proper earthing connections.

7.4.1 Ground reference plane

Where a ground reference plane (GRP) is used, it should be a metal sheet (copper or aluminium) of 0,25 mm minimum thickness. Other metals may be used, but in that case they should have 0,65 mm minimum thickness.

If the GRP is used, the EUT, auxiliary equipment, and the test equipment shall be placed on the GRP and connected to it. The connections to the GRP shall be as short as possible.

The minimum size of the GRP is 1 m × 1 m; the final size depends on the dimensions of the EUT. The GRP shall be projected beyond the EUT and its auxiliary equipment by at least 0,1 m on all sides.

The GRP shall be connected to the safety earth system of the laboratory.

7.4.2 Explicit earthing connections

Ring wave tests may be performed without a GRP in order to satisfy national safety regulations. However, repeatability may be effected. When testing is performed without the GRP, it is important to minimize coupling to other conductors (including protective earth conductors) and equipment not intended to be part of the test configuration.

To accomplish this, protective earth (PE) of each unit (test generator, coupling/decoupling network and EUT) is connected to the PE input terminal of the coupling/decoupling network.

It is also necessary that the test generator case shall be connected to the PE, but the generator output terminals shall be floating.

7.5 Equipment under test

The equipment under test shall be arranged and connected according to the equipment installation specifications.

The minimum distance between the EUT and all other conductive structures (for example, the walls of a shielded room), except the GRP beneath the EUT, shall be 0,5 m.

The operating signals for exercising the EUT may be provided by auxiliary equipment, or by a simulator.

The input and output circuits connected to auxiliary equipment shall be provided with decoupling networks to prevent interference to that equipment.

The cables supplied or specified by the equipment manufacturer shall be used or, in their absence, unshielded cables shall be adopted, of the type suitable for the signals involved.

The coupling/decoupling network shall be inserted in the circuits 1 m from the EUT and connected to the GRP.

The communication lines (data lines) shall be connected to the EUT by the cables given in the technical specification or standard for this application. They shall be elevated 0,1 m above the GRP and be at least 1 m in length.

Details for table-top and floor-standing equipment are as follows.

7.5.1 Table-top equipment

The EUT and cables shall be isolated from the GRP, if used, by an insulating support $0,1\text{ m} \pm 0,01\text{ m}$ in height.

An example of the test set-up for table-top equipment is given in Figure 3.

7.5.2 Floor-standing equipment

Where a GRP is used, floor-standing equipment shall be placed on a $0,1\text{ m} \pm 0,01\text{ m}$ thickness insulating support.

The EUT shall be connected to the earthing system according to the manufacturer's installation specifications.

The equipment cabinets shall be connected to the GRP via a connection of minimum length starting from the earth terminal of the EUT. No additional connections are allowed.

An example of the test set-up for floor-standing equipment is given in Figure 4.

7.6 Coupling/decoupling networks

If the coupling/decoupling network is a unit separated from the test generator itself, the test generator shall be placed close to the coupling/decoupling network and connected to the latter through a line no longer than 1 m in length. The coupling/decoupling networks shall be connected to the GRP, where used, through a connection as short as possible.

For an EUT that is not supplied with a mains power cable, a 1 m mains cable shall be used. If a mains cable longer than 1 m is supplied with the EUT, the excess length of the cable shall be gathered into a flat coil with 0,2 m diameter and situated at a distance of 0,1 m above the GRP.

- *EUT supplied with non-detachable molded cable*

It shall be tested with the actual length provided.

- *EUT supplied with detachable cable, molded at both ends and specified in the manufacturer's manual*

It shall be tested with the specified cable. However, if the manufacturer specifies more than one length of pre-molded cable, then the shortest length shall be used for testing.

8 Test procedure

The performance of the test equipment shall be checked prior to the test. This check can usually be limited to the existence of the ring wave at the output of the coupling/decoupling network.

The test procedure includes:

- the verification of the laboratory reference conditions;
- the preliminary verification of the correct operation of the equipment;
- the execution of the test;
- the evaluation of the test results.

If not otherwise specified in the product standard, a minimum of five positive and five negative transients shall be applied at a maximum rate of 1/s, depending on the generator impedance, EUT and other transient protectors involved in the test.

Product committees shall define the impedance of the test generator to be used for the different EUT ports and the time interval between each transient.

Information on the maximum repetition rate is given in 4.2. Other repetition rates or limits may be provided by the product standard or product specification.

8.1 Laboratory reference conditions

In order to minimize the impact of environmental parameters on test results, the tests shall be carried out in the climatic and electromagnetic reference conditions as specified in 8.1.1 and 8.1.2.

8.1.1 Climatic conditions

Unless otherwise specified by the committee responsible for the generic or product standard, the climatic conditions in the laboratory shall be within any limits specified for the operation of the EUT and the test equipment by their respective manufacturers.

Tests shall not be performed if the relative humidity is so high as to cause condensation on the EUT or the test equipment.

NOTE Where it is considered that there is sufficient evidence to demonstrate that the effects of the phenomenon covered by this standard are influenced by climatic conditions, this should be brought to the attention of the committee responsible for this standard.

8.1.2 Electromagnetic conditions

The electromagnetic conditions of the laboratory shall be such to guarantee the correct operation of the EUT in order to have no influence on the test results.

8.2 Execution of the test

The test shall be carried out on the basis of a test plan, including verification of the performances of the EUT, as defined in the product standard, or in its absence, by the technical specification.

The EUT shall be in the normal operating conditions.

The test plan shall specify:

- type of test that will be carried out;
- test level;
- test generator and the internal impedance selected for each test;
- polarity of the test voltage (both polarities are mandatory);
- number of applications of the test voltage;
- duration of the test;
- EUT ports to be tested;
- mode of application of the test voltage (line-to-ground, line-to-line, between cabinets);

- sequence of application of the test voltage to the EUT ports;
- synchronization angle and phase for testing power supply (only for ring wave);
- representative operating conditions of the EUT;
- auxiliary equipment.

The power supply, signal and other functional electrical quantities shall be applied within their rated range. If the actual operating signal sources are not available, they may be simulated. Preliminary verification of equipment performances shall be carried out on the completed test set-up before applying the test voltage.

The test voltage shall be applied to the EUT.

The EUT shall be verified according to the product standard or, in its absence, by the technical specifications, which will specify the applicability of the ring wave.

Under no circumstances shall the test level, the impedance of the generator and repetition rate exceed the product specification.

a) *Line-to-ground test*

The test voltage shall be applied, through the coupling network, between each circuit and earth (GRP).

One of the terminals of the test generator shall be connected to earth (GRP). The other terminal of the generator shall be connected through a single line to each input terminal of the coupling network in turn.

Examples of the application of the prescriptions related to the different types of EUT ports are given in the following figures:

- Figure 6 – AC./DC. power supply port, single phase, line-to-ground test;
- Figure 8 – Example of test setup for capacitive coupling on a.c. lines (3-phase); line L3 to ground coupling;
- Figure 9 – Example of test setup for unshielded unsymmetrical interconnection lines; line-to-line and line-to-ground coupling via capacitors;
- Figure 10 – Example of test setup for unshielded unsymmetrical interconnection lines; line-to-line and line-to-ground coupling via arrestors;
- Figure 11 – Example of test setup for unshielded unsymmetrical interconnection lines; line-to-line and line-to-ground coupling via a clamping circuit;
- Figure 12 – Example of test setup for unshielded symmetrical interconnection lines (communication lines); lines-to-ground coupling via arrestors.

b) *Line-to-line test*

The test voltage shall be applied, through the coupling network, between each representative combination of the terminals of the circuit under test.

The output of the test generator shall be floating.

Examples of the application of the prescriptions related to the different types of EUT ports are given in the following figures:

- Figure 5 – AC/DC power supply port, single phase, line-to-line test;
- Figure 7 – Example of test setup for capacitive coupling on a.c. lines (3-phases); line L3 to line L1 coupling;
- Figure 9 – Example of test setup for unshielded unsymmetrical interconnection lines; line-to-line and line-to-ground coupling via capacitors;
- Figure 10 – Example of test setup for unshielded unsymmetrical interconnection lines; line-to-line and line-to-ground coupling via arrestors;
- Figure 11 – Example of test setup for unshielded unsymmetrical interconnection lines; line-to-line and line-to-ground coupling via a clamping circuit.

9 Evaluation of test results

The test results shall be classified in terms of the loss of function or degradation of performance of the equipment under test, relative to a performance level defined by its manufacturer or the requestor of the test, or agreed between the manufacturer and the purchaser of the product. The recommended classification is as follows:

- a) normal performance within limits specified by the manufacturer, requestor or purchaser;
- b) temporary loss of function or degradation of performance which ceases after the disturbance ceases, and from which the equipment under test recovers its normal performance, without operator intervention;
- c) temporary loss of function or degradation of performance, the correction of which requires operator intervention;
- d) loss of function or degradation of performance which is not recoverable, owing to damage to hardware or software, or loss of data.

The manufacturer's specification may define effects on the EUT which may be considered insignificant, and therefore acceptable.

This classification may be used as a guide in formulating performance criteria, by committees responsible for generic, product and product-family standards, or as a framework for the agreement on performance criteria between the manufacturer and the purchaser, for example where no suitable generic, product or product-family standard exists.

10 Test report

The test report shall contain all the information necessary to reproduce the test. In particular, the following shall be recorded:

- the items specified in the test plan required in Clause 8 of this standard;
- identification of the EUT and any associated equipment, e.g. brand name, product type, serial number;
- identification of the test equipment, e.g. brand name, product type, serial number;
- any special environmental conditions in which the test was performed, e.g. shielded enclosure;
- any specific conditions necessary to enable the test to be performed;
- performance level defined by the manufacturer, requestor or purchaser;
- performance criterion specified in the generic, product or product-family standard;

- any effects on the EUT observed during or after the application of the test disturbance, and the duration for which these effects persist;
- the rationale for the pass/fail decision (based on the performance criterion specified in the generic, product or product-family standard, or agreed between the manufacturer and the purchaser);
- any specific conditions of use, for example cable length or type, shielding or grounding, or EUT operating conditions, which are required to achieve compliance.

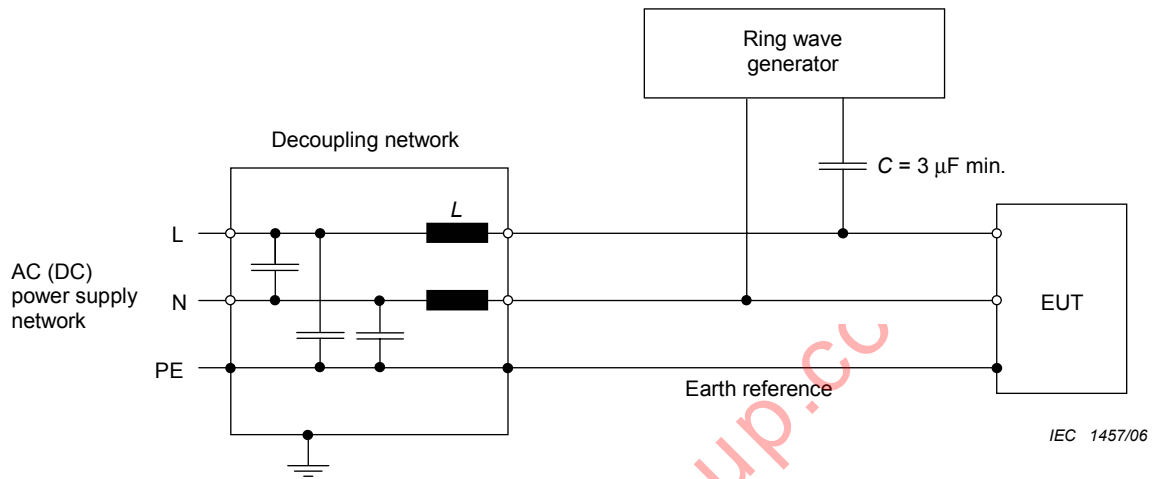

Figure 5 – AC/DC power supply port, single phase, line-to-line test

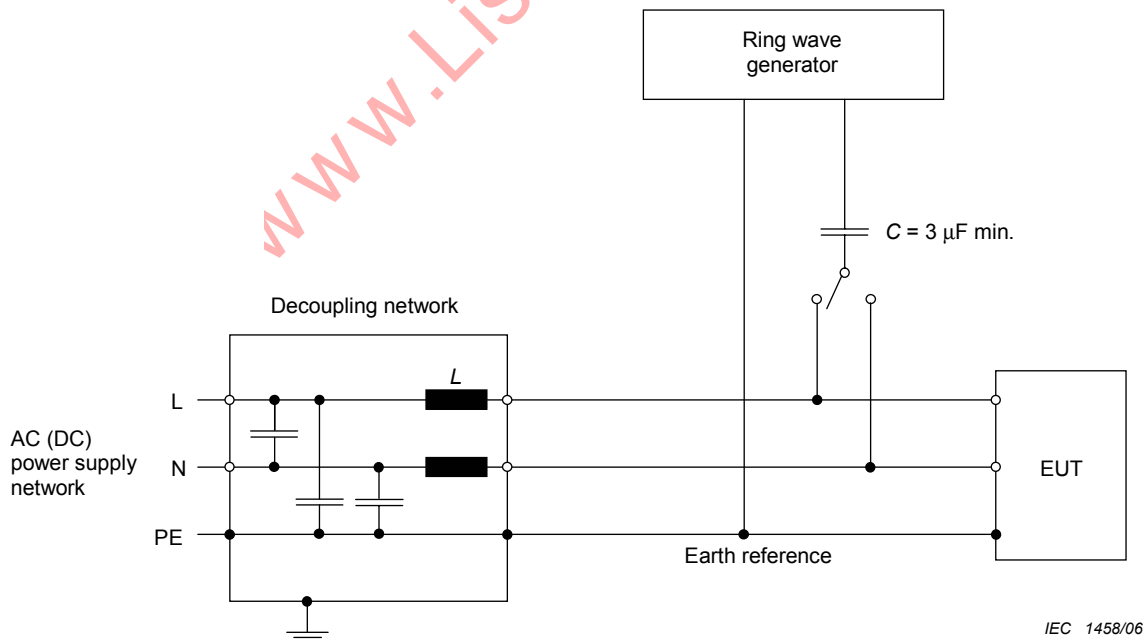
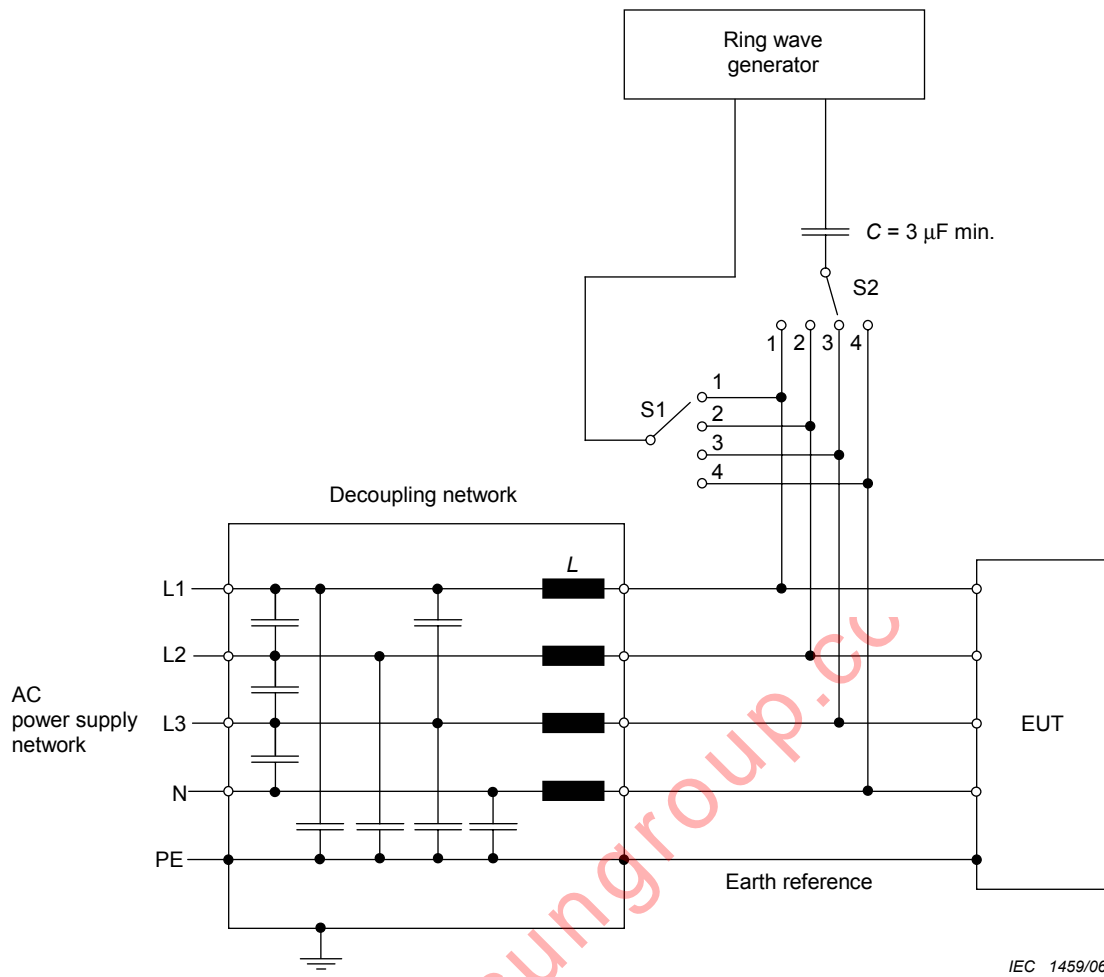

Figure 6 – AC/DC power supply port, single phase, line-to-ground test



IEC 1459/06

- 1) *Switch S1*
- line-to-line: positions 1 to 4
- 2) *Switch S2*
- during the test positions 1 to 4, but not in the same position with switch S1

Figure 7 – Example of test setup for capacitive coupling on a.c. lines (3 phases) – line L3 to line L1 coupling

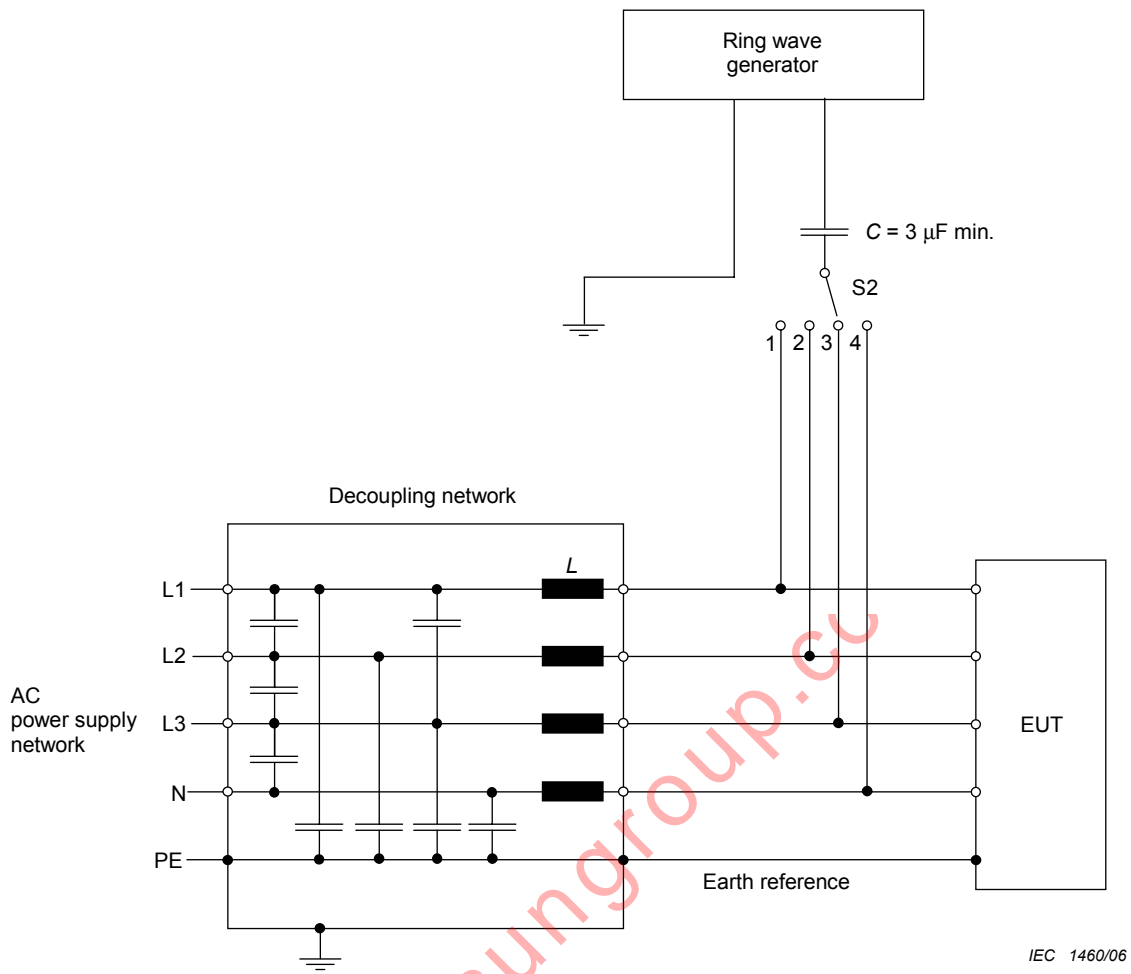

Switch S2 is used to select individual lines for test.

Figure 8 – Example of test setup for capacitive coupling on a.c. lines (3 phases) – line L3 to ground coupling

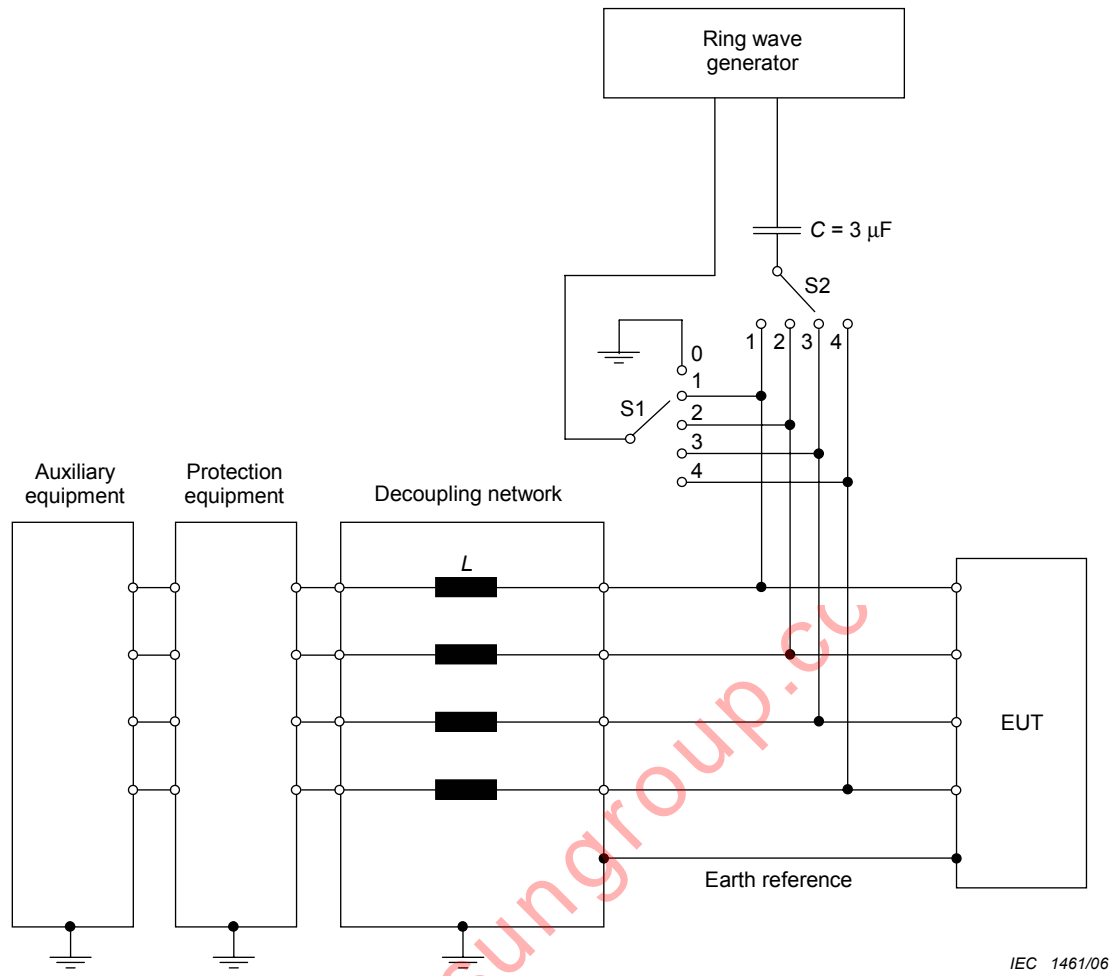

- 1) *Switch S1*
 - line-to-ground: position 0
 - line-to-line: positions 1 to 4
- 2) *Switch S2*
 - during the test positions 1 to 4, but not in the same position with switch S1

Figure 9 – Example of test setup for unshielded unsymmetrical interconnection lines – line-to-line and line-to-ground coupling via capacitors

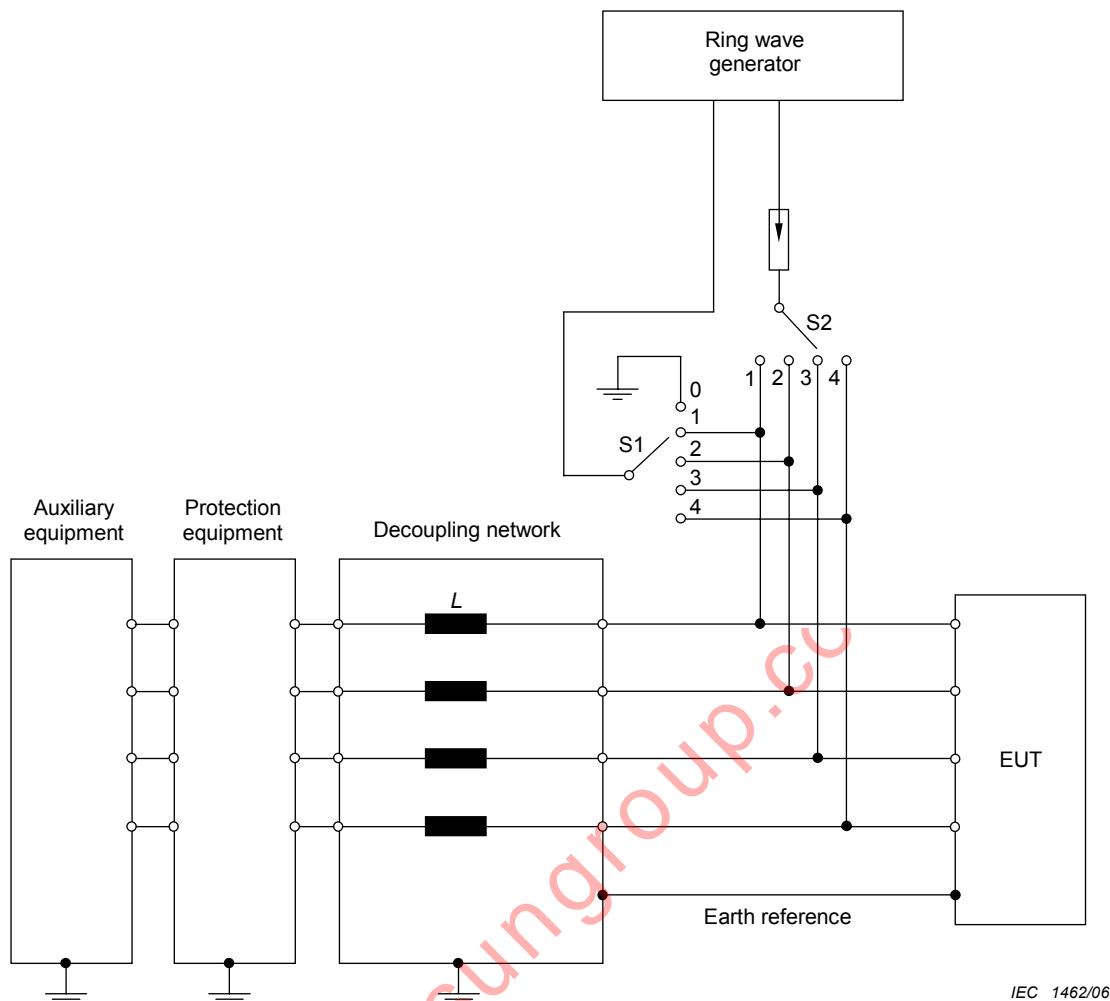

- 1) Switch S1
 - line-to-ground: position 0
 - line-to-line: positions 1 to 4
- 2) Switch S2
 - during the test positions 1 to 4, but not in the same position with switch S1

Figure 10 – Example of test setup for unshielded unsymmetrical interconnection lines – line-to-line and line-to-ground coupling via arrestors

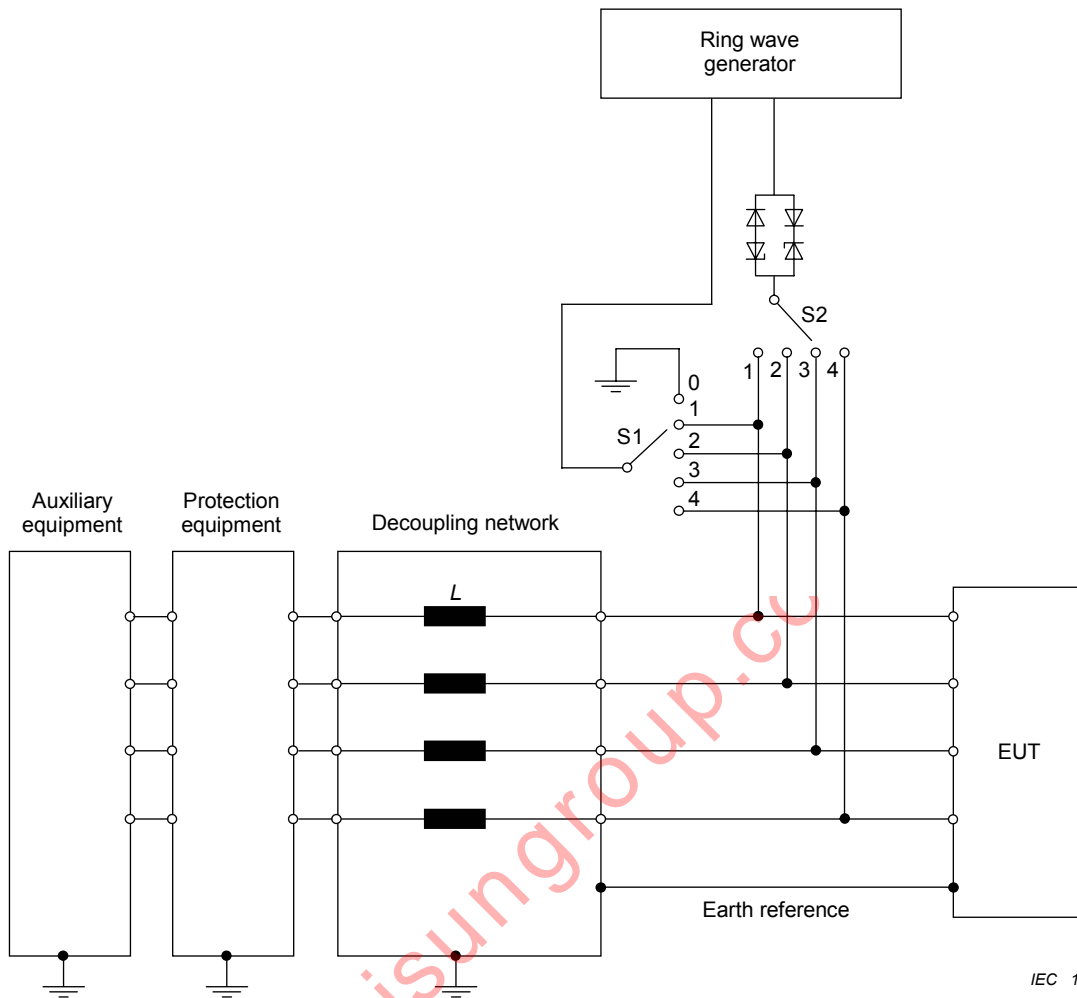

IEC 1463/06

- 1) *Switch S1*
 - line-to-ground: position 0
 - line-to-line: positions 1 to 4
- 2) *Switch S2*
 - during the test positions 1 to 4, but not in the same position with switch S1

Figure 11 – Example of test setup for unshielded unsymmetrical interconnection lines – line-to-line and line-to-ground coupling via a clamping circuit

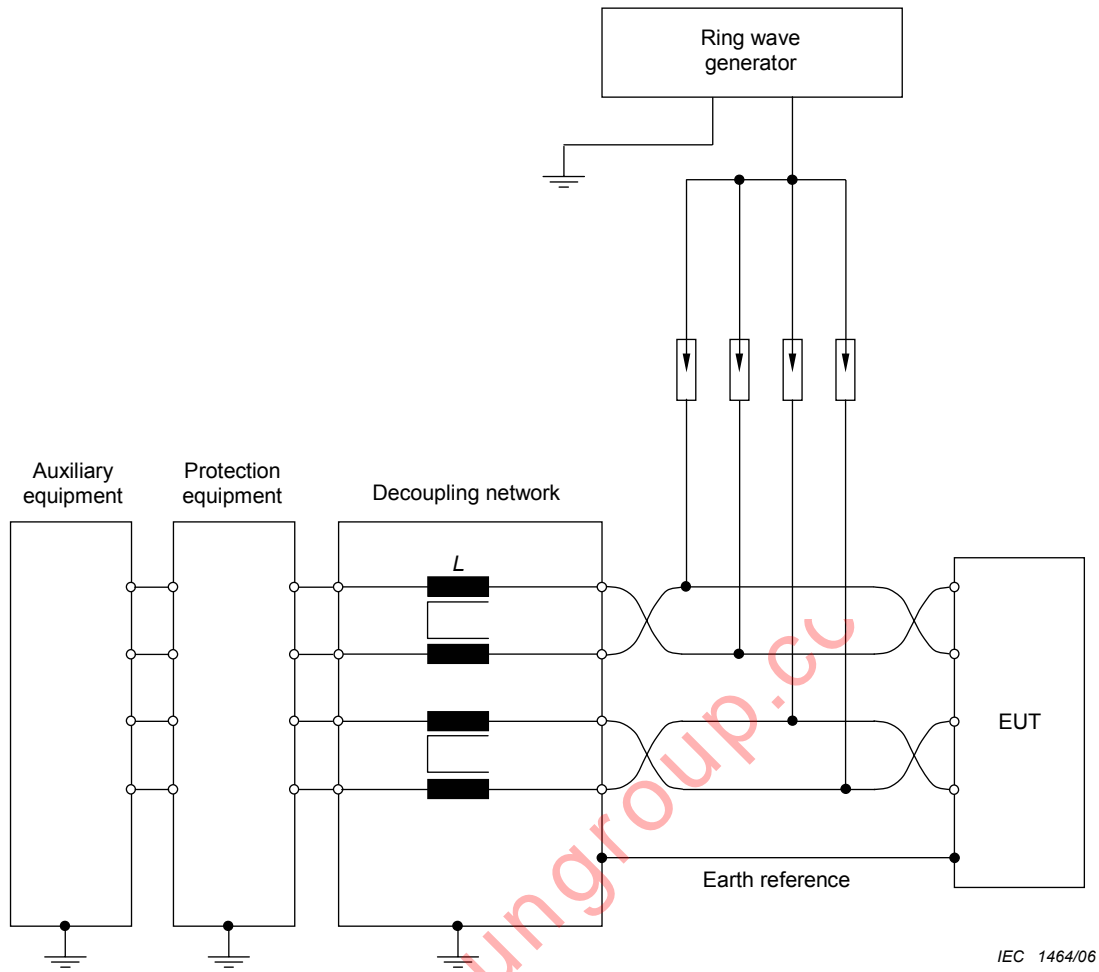

NOTE The gas arrestors shown can be replaced by a clamping circuit such as that shown in Figure 11.

Figure 12 – Example of test setup for unshielded symmetrical interconnection lines (communication lines) – lines-to-ground coupling via arrestors

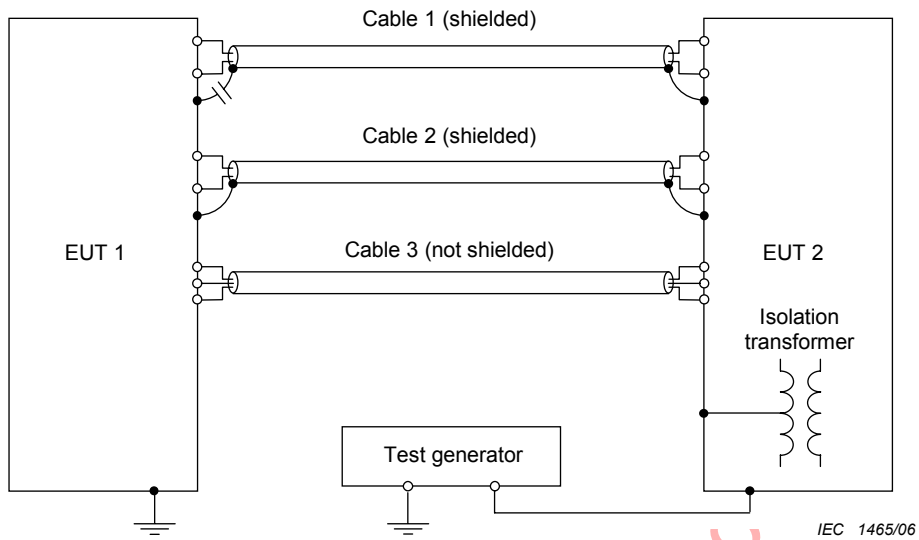

Figure 13 – Test of a system with communication ports with fast operating signals (generator output earthed)

www.Lisungroup.co.uk

Annex A (informative)

Information on test levels for the ring wave

As stated in Clause 5, the relevance of the phenomena may be used in order to determine the most appropriate test level, selected on the basis of the following guide:

Level 1

- Switching:
- power supply port connected to protected local power source (e.g. uninterruptible power system, power converter);
 - input/output ports connected to cables running in parallel with power cables of the class under consideration.
- Lightning:
- power supply, input/output ports of equipment in control room.

Level 2

- Switching:
- power supply port directly connected to mains distribution systems of residential area;
 - power supply port of equipment in industrial and electrical plants, decoupled from mains power distribution system through isolation transformers, protection devices, etc.;
 - input/output ports connected to cables running in parallel with power cables of the class under consideration.
- Lightning:
- power supply, input/output ports connected to shielded cables.

Level 3

- Switching
- power supply port connected to dedicated power distribution systems in electrical and industrial plants;
 - input/output ports connected to cables running in parallel with the power cables of the class under consideration.
- Lightning:
- power supply port connected to unshielded cables;
 - power supply, input/output ports connected to outdoor cables provided with shielding provisions (for example, metallic cable trays).

Level 4

- Switching:
- power supply port connected to power source characterized by heavy inductive loads in industrial or electrical plants;
 - input/output ports connected to cables running in parallel with the power cables of the class under consideration.
- Lightning:
- power supply, input/output ports connected to outdoor cables without shielding provisions.

- Level x** Special situations to be analyzed.

Bibliography

IEC 60050-300, *International Electrotechnical Vocabulary – Electrical and electronic measurements and measuring instruments – Part 311: General terms relating to measurements – Part 312: General terms relating to electrical measurements – Part 313: Types of electrical measuring instruments – Part 314: Specific terms according to the type of instrument*

IEC 60068-1: *Environmental testing – Part 1: General and guidance*

NOTE Harmonized as EN 60068-1:1994 (not modified).

IEC 60816: *Guide on methods of measurement of short duration transients on low voltage power and signal lines*

IEC 61000-4-5, *Electromagnetic compatibility (EMC) – Part 4-5: Testing and measurement techniques – Surge immunity test*

NOTE Harmonized as EN 61000-4-5:2006 (not modified).

IEC 61010-1: *Safety requirements for electrical equipment for measurement, control and laboratory use – Part 1: General requirements*

NOTE Harmonized as EN 61010-1:2001 (not modified).

www.Lisungroup.co

Annex ZA
(normative)

**Normative references to international publications
with their corresponding European publications**

The following referenced documents are indispensable for the application of this document. For dated references, only the edition cited applies. For undated references, the latest edition of the referenced document (including any amendments) applies.

NOTE When an international publication has been modified by common modifications, indicated by (mod), the relevant EN/HD applies.

<u>Publication</u>	<u>Year</u>	<u>Title</u>	<u>EN/HD</u>	<u>Year</u>
IEC 60050-161	- ¹⁾	International Electrotechnical Vocabulary (IEV) Chapter 161: Electromagnetic compatibility	-	-

www.Lisungroup.cc

¹⁾ Undated reference.

www.Lisungroup.cc

BSI — British Standards Institution

BSI is the independent national body responsible for preparing British Standards. It presents the UK view on standards in Europe and at the international level. It is incorporated by Royal Charter.

Revisions

British Standards are updated by amendment or revision. Users of British Standards should make sure that they possess the latest amendments or editions.

It is the constant aim of BSI to improve the quality of our products and services. We would be grateful if anyone finding an inaccuracy or ambiguity while using this British Standard would inform the Secretary of the technical committee responsible, the identity of which can be found on the inside front cover.
Tel: +44 (0)20 8996 9000. Fax: +44 (0)20 8996 7400.

BSI offers members an individual updating service called PLUS which ensures that subscribers automatically receive the latest editions of standards.

Buying standards

Orders for all BSI, international and foreign standards publications should be addressed to Customer Services. Tel: +44 (0)20 8996 9001.
Fax: +44 (0)20 8996 7001. Email: orders@bsi-global.com. Standards are also available from the BSI website at <http://www.bsi-global.com>.

In response to orders for international standards, it is BSI policy to supply the BSI implementation of those that have been published as British Standards, unless otherwise requested.

Information on standards

BSI provides a wide range of information on national, European and international standards through its Library and its Technical Help to Exporters Service. Various BSI electronic information services are also available which give details on all its products and services. Contact the Information Centre.
Tel: +44 (0)20 8996 7111. Fax: +44 (0)20 8996 7048. Email: info@bsi-global.com.

Subscribing members of BSI are kept up to date with standards developments and receive substantial discounts on the purchase price of standards. For details of these and other benefits contact Membership Administration.
Tel: +44 (0)20 8996 7002. Fax: +44 (0)20 8996 7001.
Email: membership@bsi-global.com.

Information regarding online access to British Standards via British Standards Online can be found at <http://www.bsi-global.com/bsonline>.

Further information about BSI is available on the BSI website at <http://www.bsi-global.com>.

Copyright

Copyright subsists in all BSI publications. BSI also holds the copyright, in the UK, of the publications of the international standardization bodies. Except as permitted under the Copyright, Designs and Patents Act 1988 no extract may be reproduced, stored in a retrieval system or transmitted in any form or by any means – electronic, photocopying, recording or otherwise – without prior written permission from BSI.

This does not preclude the free use, in the course of implementing the standard, of necessary details such as symbols, and size, type or grade designations. If these details are to be used for any other purpose than implementation then the prior written permission of BSI must be obtained.

Details and advice can be obtained from the Copyright & Licensing Manager.
Tel: +44 (0)20 8996 7070. Fax: +44 (0)20 8996 7553.
Email: copyright@bsi-global.com.